



## SUBMITTAL DATA SHEET

Ceiling&Floor Heat Pump System	ACiQ-48ZPL-HP230B/ ACiQ-48FM-HH-MB
Location: _____ Engineer: _____ Submitted to: _____ Submitted by: _____ Reference: _____	Approval: _____ Date: _____ Construction: _____ Unit #: _____ Drawing #: _____

<b>Set Code</b>	22022710003696
Indoor unit code	22022711000658
Outdoor unit code	22022516001922
<b>Set Model</b>	
Indoor unit model	ACiQ-48FM-HH-MB
Outdoor unit model	ACiQ-48ZPL-HP230B
<b>Certified</b>	AHRI
	CSA



SYSTEM PERFORMANCE DATA		
<b>Power supply</b>		
Normal Operational Voltage	(V, Ph, Hz)	208/230V, 1Ph, 60Hz
Voltage Range	(V)	187-253
<b>Electrical</b>		
Minimum circuit ampacity(Outdoor)	(A)	42.0
Max.fuse(Outdoor)	(A)	50.0
Connection wiring		14AWG*2 Stranded, shielded
<b>Cooling</b>		
Capacity	(Btu/h)	48000(2150~48000)
Power Input	(W)	5930(575~5800)
Current	(A)	24.86(4.51~25.41)
SEER2	(Btu/W)	17.0
EER2	(Btu/W)	8.2
<b>Heating</b>		
Capacity	(Btu/h)	51000(11800~56300)
Power Input	(W)	5150(670~5590)
Current	(A)	20.60(4.98~24.48)
HSPF2-4	(Btu/W)	9.8
HSPF2-5	(Btu/W)	7.5
COP	W/W	2.90
Heat at 17F(H32)	(Btu/h)	35000
Heat at 5F(H42)	(Btu/h)	49000
COP at 5F(H42)	W/W	1.80

INDOOR UNIT DATA		
<b>Indoor fan motor</b>		
Model		ZKFN-90-8-1
Qty		1
Input	(W)	96.0
Output	(W)	90.0
RLA	(A)	1.80
Speed(Hi/Mi/Lo)	(r/min)	1320/1200/1120
<b>Air flow &amp; Noise level</b>		
Indoor air flow (Hi/Med/Lo) (No duct)	(CFM)	//1352.94/1117.65/1000.00
Indoor noise level (Hi/Med/Lo)	[dB(A)]	55/50/44
<b>Dehumidification</b>		
	(L/H)	6.22
<b>Indoor unit</b>		
Dimension (WxDxH)	(inch)	64.96x26.57x9.25
	(mm)	1650x675x235
Packing(WxDxH)	(inch)	67.91x29.72x12.52
	(mm)	1725x755x318
Net/Gross weight	(lbs.)	87.74/102.29
	(kg)	39.8/46.4

REFRIGERANT PIPE DATA		
Throttle type	Indoor unit	N/A
	Outdoor unit	EXV+Throttle valve
Design pressure	(PSIG)	550/340
Refrigerant Type		R410A
Refrigerant charge	oz	148.00
	(ft)	25.0
Refrigerant precharge	(m)	7.5
Additional charge for each ft	(oz/ft)	0.32
Additional charge for each m	(g/m)	30.0
Liquid side/ Gas side(indoor)	(inch)	3/8"/5/8"
	(mm)	9.52/15.9
Liquid side/ Gas side(outdoor)	(inch)	3/8"/5/8"
	(mm)	9.52/15.9
Max. pipe length	(ft)	213.3

OUTDOOR UNIT DATA		
<b>Compressor</b>		
Type		ROTARY
Model		EAPQ420D1UMUA
Brand		GMCC
Capacity	(Btu/h)	44015
Input	(W)	3565
Rated current (RLA)	(A)	33.0
Refrigerant oil/oil charge	(ml)	1460±15mlESTER OIL VG74
<b>Outdoor fan motor</b>		
Model		ZKFN-85-8-22-5
Qty		2
Input	(W)	126.00
Output	(W)	85.00
RLA	(A)	1.20
Speed	(r/min)	900/850/800/750
<b>Air flow &amp; Noise level</b>		
Outdoor air flow (Max.)	(CFM)	4500.0

Max. pipe length	(m)	65.0
	(ft)	98.4
Max. difference in level	(m)	30.0
Connection method		Flared
Indoor(cooling)	(Deg. °F)	62~90
	(Deg. °C)	17~32
Indoor(heating)	(Deg. °F)	32~86
	(Deg. °C)	0~30
Outdoor(cooling)	(Deg. °F)	5~122
	(Deg. °C)	-15~50
Outdoor(heating)	(Deg. °F)	-22~75
	(Deg. °C)	-30~24

Outdoor noise level	[dB(A)]	65.0
<b>Outdoor unit</b>		
Dimension (W×D×H)	(inch)	37.48x16.34x52.48
	(mm)	952x415x1333
Packing (W×D×H)	(inch)	43.11x19.49x58.27
	(mm)	1095x495x1480
Net/ Gross weight	(lbs.)	227.07/255.73
	(kg)	103/116

### Indoor unit dimension

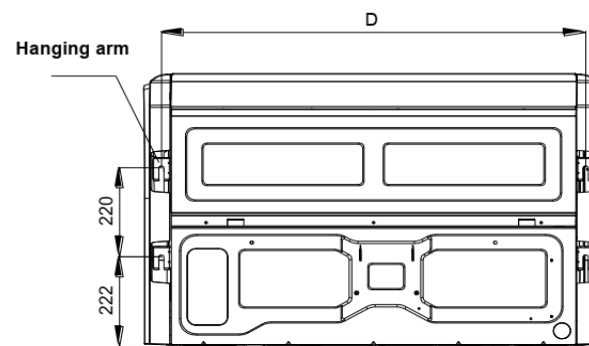
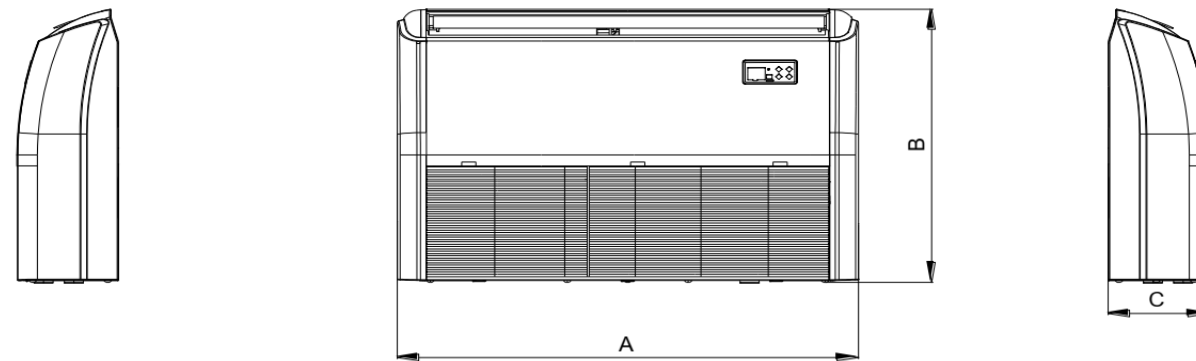
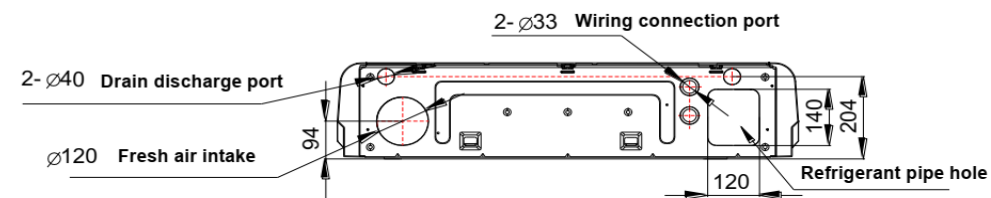

Capacity (Btu/h)	Unit	A	B	C	D
18K / 24K	mm	1068	675	235	983
	inch	42.05	26.57	9.25	38.70
36K	mm	1285	675	235	1200
	inch	50.59	26.57	9.25	47.24
48K/60K	mm	1650	675	235	1565
	inch	64.96	26.57	9.25	61.61

### Outdoor unit dimension

